



Constantly innovating media communication through the fusion of broadcasting and communication. What kind of marketing, branding and new business possibilities will develop from the front-line of broadcasting and communication, such as advancing digital technology and 5G? INTER BEE CONNECTED provides a platform for exhibits and presentations that CONNECT to the next digital business.

2018 Actual

- ◇ Exhibitors: **13** companies ◇ Exhibitor's presentation: **11**
- ◇ Planned Sessions: **13** ◇ Number of audience: **2,544** people

Type of Business

Comparison of participants for CONNECTED with Inter BEE over all.

Type of Business	CONNECTED	Overall	Type of Business	CONNECTED	Overall
Commercial TV Broadcaster	34.6%	9.0%	Telecommunications Carrier	3.1%	3.3%
Public Broadcast Station	6.0%	3.4%	Post Production	3.0%	6.7%
Equipment Manufacture	5.6%	12.0%	Production	2.8%	3.9%
Other User	5.3%	9.4%	Radio Station	2.4%	0.7%
Related CATV	4.9%	2.1%	Student	1.8%	7.8%
Related Internet Business	4.9%	3.3%	Trading Company	0.9%	5.7%
Content Delivery Network	4.8%	1.3%	Related Staging, Art and Lighting	0.4%	2.7%
Film and Video Production Company	4.4%	5.9%	Related PA Equipment	0.3%	3.9%
Other Guest	4.0%	8.7%	Facilities and Stores	0.3%	1.5%
Related Content Creation	3.7%	4.0%	Video Software Production Company	0.2%	0.7%
Ad Agency	3.5%	1.3%	Recording Company	0.1%	0.5%
Government Office, Organization	3.2%	2.0%	No Answer	0.0%	0.1%

Details of participants of TV Broadcasters

Sampled data from type of occupation in TV broadcasters only

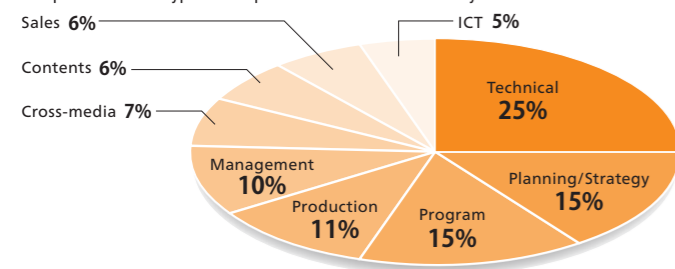

Intended Exhibitors

- ◆ Digital content production companies
- ◆ App production companies
- ◆ Digital marketing tool development companies
- ◆ Digital ad technology development-related companies
- ◆ Content production and app development support technology - related companies
- ◆ Digital content distribution operators
- ◆ Online platform - related operators
- ◆ Online advertising companies
- ◆ Cloud - related operators
- ◆ Communication - related operators
- ◆ Other companies and organizations involved in video and ICT

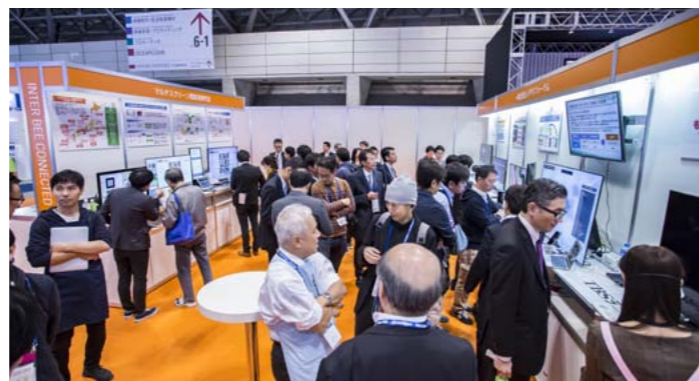

Participation fee

Exhibition Unit Counter: Type A

990mm (Frontage) × 2,400mm (Height) × 700mm (Depth)

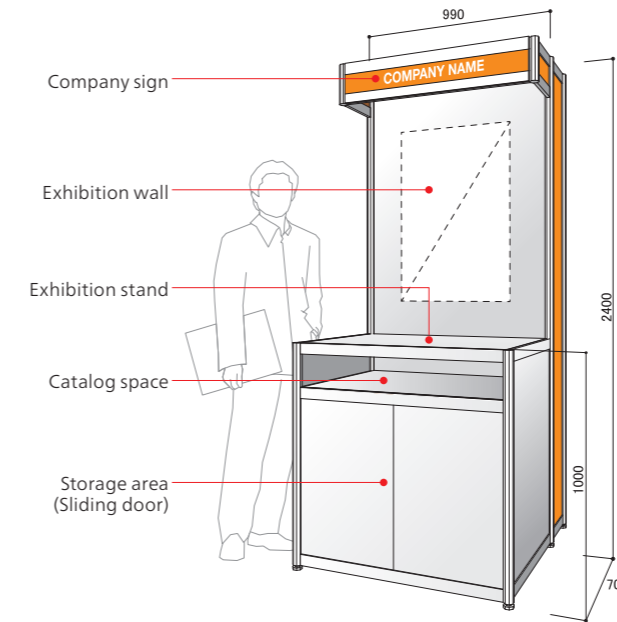

231,000 yen (incl. consumption tax)

Exhibition Unit Counter: Type B

1,980mm (Frontage) × 2,400mm (Height) × 700mm (Depth)

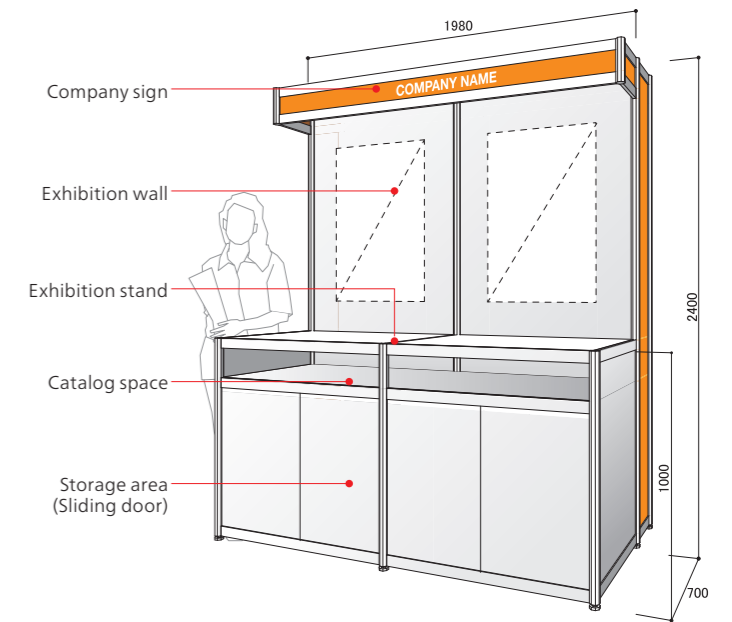

319,000 yen (incl. consumption tax)

*For consumption tax, the rate of tax as of November 2019, when this exhibition is held, will be applied.

Inclusions in the Exhibition Participation Fees

- ◇ Exhibition unit counter: Basic exhibition stand, exhibition back wall, company sign, electrical work (capacity: 1kw / 2 outlets) and Internet access
 - *Exhibition Unit Type B is including 1kW electric-supply only.
 - *If you need more than 1kW electric-supply, we charge 9,900 yen per 1kW for additional electric work.
 - *The Internet access is a shared line. There will be a separate fee if you wish to use an exclusive line.
- ◇ Presentation slot: 15 minutes per a day.
- ◇ Listing of exhibitor name and exhibition information on our official website.
- ◇ We will provide invitation leaflets
- ◇ In addition, we will treat your exhibit in accordance with that of regular exhibitors. Please refer to the information on the Inter BEE 2019 exhibition.

Outline

Name: INTER BEE CONNECTED
 Period: November 13 (Wed.) to 15 (Fri.), 2019
 Time: 10:00 to 17:30 on Nov. 13 and 14
 10:00 to 17:00 on Nov. 15
 Venue: Exhibition Hall, Makuhari Messe
 Admission: Free (Registration required)

Operation schedule

Late August	▶ Exhibitor Orientation
Fri., August 30	▶ Deadline for the payment of the exhibition fees
Late September	▶ Distribution of Inter BEE 2019 invitation leaflets
	▶ Distribution of exhibitor badges and loading/unloading vehicle stickers
Tue., November 12	▶ Setting Up

Application Deadline: Friday, June 28, 2019

- ◇ Please transfer a payment to our designated bank account by Friday, August 30.
- ◇ If an exhibitor cancels or reduces the number of booth spaces applied for, regardless of the reason, some or all of the following cancellation fees will apply. Consumption tax will be added to all fees.

July 1st to July 31st, 2019	▶ 60% of exhibition booth fee
August 1st to August 31st, 2019	▶ 80% of exhibition booth fee
On or after September 1st, 2019	▶ 100% of exhibition booth fee

How to apply/Inquiry

To apply for participation, please fill in the information required on the application form and submit the form to the Show Management Secretariat as below.

Japan Electronics Show Association

TEL: +81-3-6212-5231
 E-mail: contact2019@inter-bee.com
 Address: 5F Ote Center Bldg., 1-1-3 Otemachi, Chiyoda-ku, Tokyo, 100-0004