

Inter BEE

International Broadcast Equipment Exhibition

November 17-19, 2010
Makuhari Messe, Tokyo Japan

Organizer: **JEITA** Japan Electronics and Information Technology Industries Association

CROSS MEDIA ZONE

Pavilion Exhibit Information

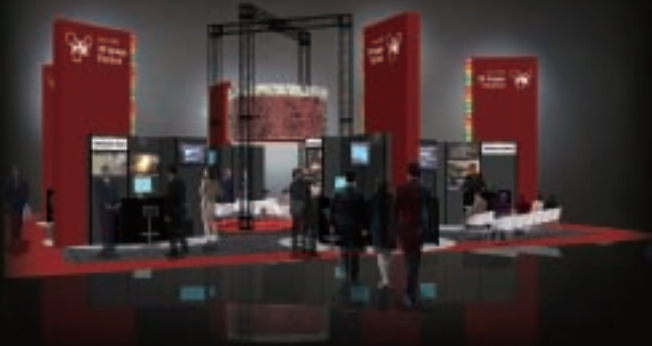

We are going to provide visitors with opportunities to create new business by creating a core of Cross-media zone and properly attracting visitors.

We have established package booths for exhibitors to exhibit their products without too much burden.

Please take this opportunity to participate in the show.



IPTV Pavilion

We have established a zone for IPTV related products in order to meet the high expectations of the visitors.



Mobile TV Pavilion

We aim to create an exhibition which enables visitors to get one step ahead to see business opportunities for the post digitalization era.



Digital Cinema Pavilion

You will be able to experience new media possibilities and technology which enables you to broaden your market.



Digital Signage Pavilion

The latest digital technology and communication systems which support new video businesses will be showcased under one roof.



3D Image Pavilion

The Video Industry's technological innovation will rapidly move toward 3D and give visitors new experiences.

■Website

The Professional Information Site for Audio, Video and Communications

InterBEE online
www.inter-bee.com

Benefit of participation / Exhibition Items

PR Support

- We are going to create publicity by giving each pavilion its own theme, integrating exhibitor's information, and actively developing pre-event PR activities.
- The Inter BEE Website publishes news articles based on pre-event interviews and "Inter BEE TV" shows videos taken during the event.

Visitor Attraction

- Visitors will be chosen from the visitor database maintained by Inter BEE and information sorted by pavilion will be provided to them to ensure each pavilion attracts the right visitors.
- With cooperation from relevant industry associations including visitor companies, we are going to publicize pavilions to member companies to attract new visitors.

Workshop

- In order to attract visitors, we are going to plan workshops according to pavilion themes. We are going to provide participating companies with workshop sites for free and introduce the programs as Inter BEE's official programs at every opportunity.

Same levels of services as the normal exhibitors

- Pavilion exhibitors benefit from all the services provided to normal exhibitors by Inter BEE.

IPTV Pavilion

Exhibition items: Video compression techniques, Video editing / control systems, Video delivery systems / services, Data broadcasting systems, Video-on-demand systems, Software, Other related techniques / products / services

Targeted visitors: Broadcasting Companies, Communication Companies, Video Production Companies, Video Distribution Companies, Electrical Manufacturers, etc.

Mobile TV Pavilion

Exhibition items: Video editing systems for mobile terminals, Video delivery systems for mobile, Mobile contents/applications, Mobile terminal equipment, Wireless systems, Wi-Fi/WiMAX, LTE, Other related techniques/products/services

Targeted visitors: Broadcasters, Telecommunication Carriers, Video Production, Video Content Delivery Network, Automobile, Electrical Manufacturers, etc.

Digital Cinema Pavilion

Exhibition items: Digital cinema filming systems, Digital cinema editing systems, Digital cinema delivery systems, Digital cinema servers, Projection systems, Contents, Other related techniques / products / services

Targeted visitors: Broadcasters, Video Production, Video Content Delivery, Network, Filming, Electrical Manufacture, etc.

Digital Signage Pavilion

Exhibition items: Digital signage editing / control systems, Image receiving systems, Video content delivery systems, Communication network services, Advertising media services, Contents, Other related techniques / products / services

Targeted visitors: Broadcasters, Video Production, Video Content Delivery, Network, Management for Facilities / Hall / Arena / Recreation Hall, Transport Facilities, Advertisement Company, Electrical, Manufacture, etc.

3D Image Pavilion

Exhibition items: 3D image output systems, 3D image editing systems, 3D image receivers / terminals / systems, 3D screening systems, 3D contents, Other related techniques / products / services

Targeted visitors: Broadcasters, Video Production, Video Content Delivery, Network, Filming, Electrical Manufacture, etc.

Exhibition type and price

Platinum Booth

Packages which focus on presentation

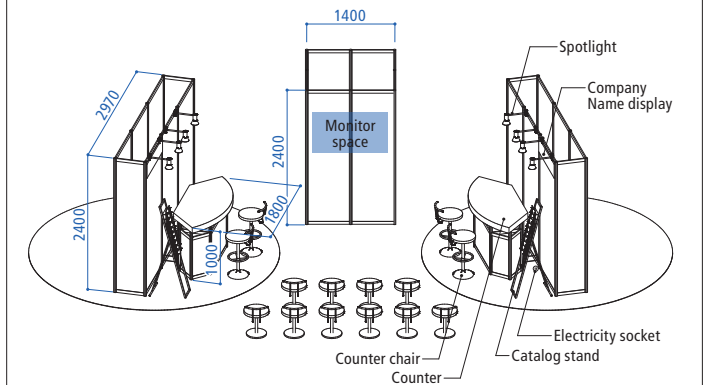

Price: **1,575,000** YEN

Specification: 12m²

Facilities: Spotlight, Company name display, (4)Electricity socket, (2)Counters, (2)Chairs, Monitor rack, (10) chairs for audience, (2)Catalog stand

Gold booth

Efficient Standard Packages

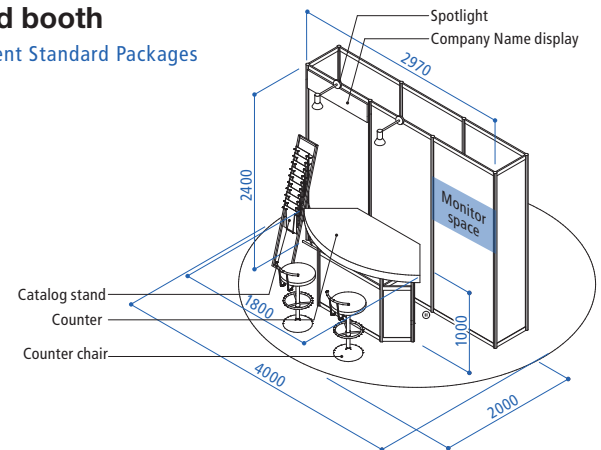

Price: **525,000** YEN

Specification: (W)4m×(D)2m

Facilities: (2)Spotlight, Company name display, (2)Electricity socket, Counter, (2)Chairs, Catalog stands

Silver Booth

Minimum Packages which prioritize cost performance

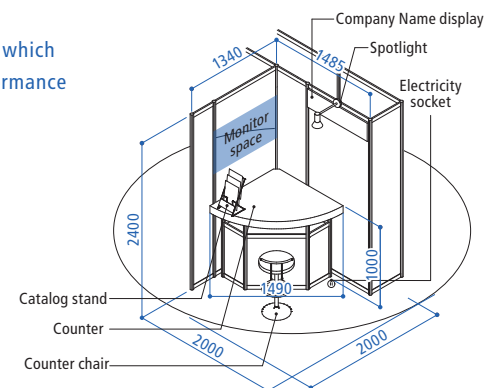

Price: **315,000** YEN

Specification: (W)2m×(D)2m

Facilities: (1)Spotlight, Company name display, (2)Electricity socket, Counter, (1)Counter Chair, Catalog stands

Important: We strongly encourage you to read the attached Exhibition Regulations. Booth positions will be decided by the Organizing Committee.